

CLASS 150 STAINLESS STEEL GATE VALVE

Fig# GT 150SSF10

Applicable Standards:

Steel Gate valves, API 603

Steel Gate valves, ASME B16.34

Face to Face, ASME B16.10

End Flange, ASME B16.5

Inspection and Test, API 598

Design:

OS&Y, Outside Screw and Yoke

Flexible Wedge

Forged T-head Stem

Rising stem and Non-rising handwheel

Valve MFG in Accordance with NACE MR0175 Specifications

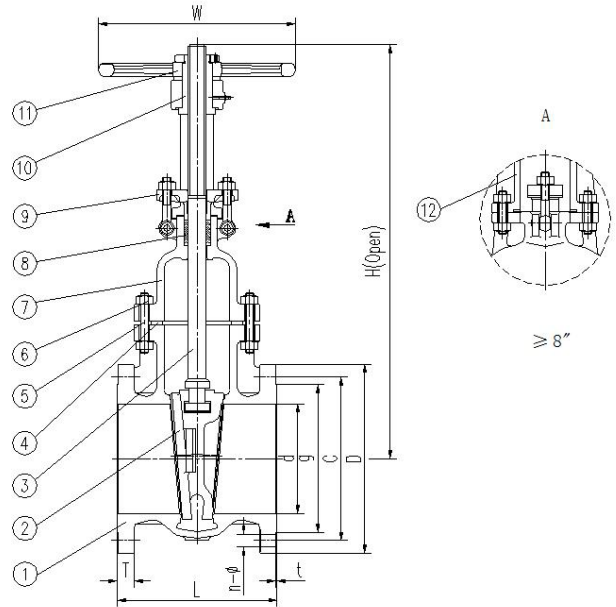

NO	PART NAME	MATERIAL
1	Body	A351-CF8M
2	Disc	A351-CF8M
3	Stem	A276-316
4	Gasket	PTFE/316+PTFE
5	Bonnet	A351-CF8M
6	Bonnet Bolt	A193-B8M

NO	PART NAME	MATERIAL
7	Nut	A194-8M
8	Packing	PTFE
9	Gland Flange	A351-CF8
10	Stem Nut	A439-D2
11	Handwheel	A395-65-45-15
12	Yoke	A351-CF8

NPS	Typical Dimensions(in)				Class 150Lb Flange Dimensions(in)							WT Lbs
	d	L	H	W	D	C	g	T	t	n	Φ	
1/2	1/2	4.25	7.72	3.94	3.5	2.38	1.38	0.37	0.06	4	5/8	7.04
3/4	3/4	4.6	8.19	3.94	3.88	2.75	1.69	0.4	0.06	4	5/8	8.14
1	1	5	8.66	3.94	4.25	3.12	2	0.44	0.06	4	5/8	10.34
1.1/2	1.1/2	6.5	10.87	5.43	5	3.88	2.88	0.56	0.06	4	5/8	17.82
2	2	7	12.87	6.3	6	4.75	3.62	0.62	0.06	4	3/4	26.4
2.1/2	2.1/2	7.5	15.67	7.87	7	5.5	4.12	0.68	0.06	4	3/4	38.5
3	3	8	17.24	7.87	7.5	6	5	0.75	0.06	4	3/4	44.88
4	4	9	20.31	8.82	9	7.5	6.19	0.94	0.06	8	3/4	68.86
5	5	10	26.5	11.02	10	8.5	7.31	0.94	0.06	8	7/8	114.4
6	6	10.5	28.62	11.02	11	9.5	8.5	1	0.06	8	7/8	126.5
8	8	11.5	36.34	11.81	13.5	11.75	10.62	1.12	0.06	8	7/8	215.6
10	10	13	44.49	13.78	16	14.25	12.75	1.18	0.06	12	1	325.6
12	12	14	54.57	17.72	19	17	15	1.25	0.06	12	1	521.4
14	14	15	62.99	19.69	21	18.75	16.25	1.37	0.06	12	1.1/8	836
16	16	16	69.45	21.65	23.5	21.25	18.5	1.44	0.06	16	1.1/8	1036
18	18	17	76.22	23.62	25	22.75	21	1.56	0.06	16	1.1/4	1258
20	20	18	85	23.62	27.5	25	23	1.68	0.06	20	1.1/4	1593
24	24	20	101.46	27.56	32	29.5	27.25	1.87	0.06	20	1.3/8	2187