

CLASS 300 STAINLESS STEEL GLOBE VALVE

Fig# GL 300SSF10

Applicable Standards:

Steel Globe valves, ASME B16.34

Face to Face, ASME B16.10

End Flange, ASME B16.5

Inspection and Test, API 598

Design:

OS&Y, Outside Screw and Yoke

Forged T-head Stem

Rising stem and Non-rising handwheel

Valve MFG in Accordance with NACE MR0175 Specifications

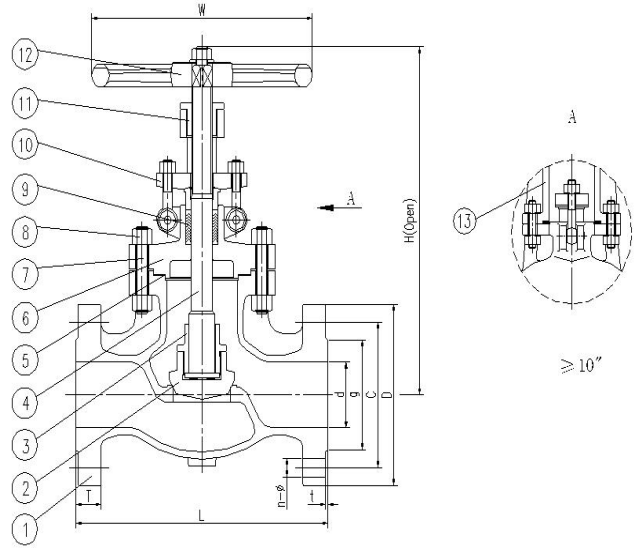

| NO | PART NAME | MATERIAL |
|----|-------------|---------------|
| 1 | Body | A351-CF8M |
| 2 | Disc | A182-F316 |
| 3 | Disc Cap | A351-CF8M |
| 4 | Stem | A276-316 |
| 5 | Gasket | PTFE/316+PTFE |
| 6 | Bonnet | A351-CF8M |
| 7 | Bonnet Bolt | A193-B8M |

| NO | PART NAME | MATERIAL |
|----|--------------|---------------|
| 8 | Nut | A194-8M |
| 9 | Packing | PTFE |
| 10 | Gland Flange | A351-CF8 |
| 11 | Stem Nut | A439-D2 |
| 12 | Handwheel | A395-65-45-15 |
| 13 | Yoke | A351-CF8 |

| NPS | Typical Dimensions(in) | | | | Class 300Lb Flange Dimensions(in) | | | | | | | WT Lbs |
|-------|------------------------|-------|-------|-------|-----------------------------------|-------|-------|------|------|----|-------|-----------|
| | d | L | H | W | D | C | g | T | t | n | Φ | |
| 1/2 | 1/2 | 6 | 7.6 | 3.94 | 3.75 | 2.62 | 1.38 | 0.56 | 0.06 | 4 | 5/8 | 8.8 |
| 3/4 | 3/4 | 7 | 7.6 | 3.94 | 4.62 | 3.25 | 1.69 | 0.62 | 0.06 | 4 | 3/4 | 11 |
| 1 | 1 | 8 | 8.82 | 5.43 | 4.88 | 3.5 | 2 | 0.68 | 0.06 | 4 | 3/4 | 16.5 |
| 1.1/2 | 1.1/2 | 9 | 10.39 | 7.87 | 6.12 | 4.5 | 2.88 | 0.81 | 0.06 | 4 | 7/8 | 27.5 |
| 2 | 2 | 10.5 | 10.87 | 7.87 | 6.5 | 5 | 3.62 | 0.87 | 0.06 | 8 | 3/4 | 35.6 |
| 2.1/2 | 2.1/2 | 11.5 | 15.31 | 9.84 | 7.5 | 5.88 | 4.12 | 1 | 0.06 | 8 | 7/8 | 83.6 |
| 3 | 3 | 12.5 | 15.94 | 11.02 | 8.25 | 6.62 | 5 | 1.12 | 0.06 | 8 | 7/8 | 85.8 |
| 4 | 4 | 14 | 18.46 | 13.78 | 10 | 7.88 | 6.19 | 1.25 | 0.06 | 8 | 7/8 | 146.1 |
| 5 | 5 | 15.75 | 22.72 | 17.72 | 11 | 9.25 | 7.31 | 1.37 | 0.06 | 8 | 7/8 | 275 |
| 6 | 6 | 17.5 | 27.17 | 15.75 | 12.5 | 10.62 | 8.5 | 1.44 | 0.06 | 12 | 7/8 | 301.4 |
| 8 | 8 | 22 | 35.91 | 17.72 | 15 | 13 | 10.62 | 1.62 | 0.06 | 12 | 1 | 502 |
| 10 | 10 | 24.5 | 37.36 | 23.62 | 17.5 | 15.25 | 12.75 | 1.87 | 0.06 | 16 | 1.1/8 | 1030 |
| 12 | 12 | 28 | 40.63 | 27.56 | 20.5 | 17.75 | 15 | 2 | 0.06 | 16 | 1.1/4 | 1373 |