

CLASS 150 CARBON STEEL FLOATING BALL VALVE

Fig# BL 150CS

Applicable Standards:

Steel Ball valves, ASME B16.34

Face to Face, ASME B16.10

End Flange, ASME B16.5

Inspection and Test, API 598

Design:

Valve MFG in Accordance with NACE

MR0175 Specifications

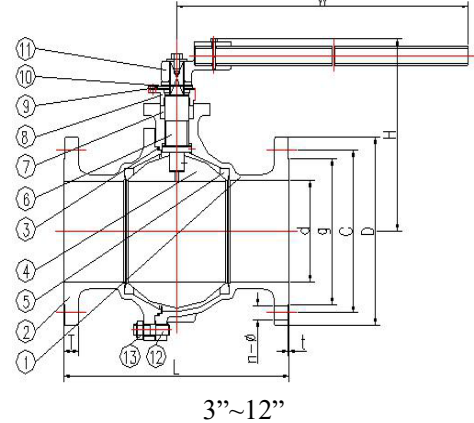
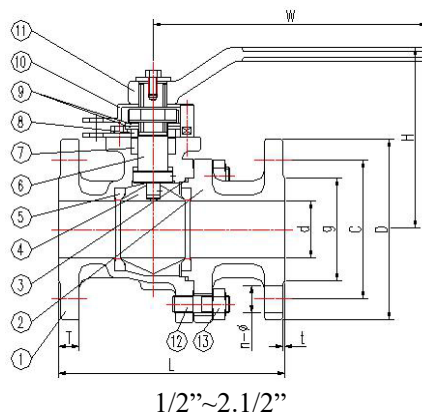

NO	PART NAME	MATERIAL
1	Body	A216-WCB
2	Bonnet	A216-WCB
3	Gasket	304+Graphite
4	Ball	A276-316
5	Ball Seats	PTFE/TFM1600
6	Stem	A276-316
7	Packing	PTFE/Graphite

NO	PART NAME	MATERIAL
8	Gland Flange	A216-WCB
9	Belleville Washers	A276-301
10	Lock Plate	A276-304
11	Lever	Steel
12	Bonnet Bolt	A193-B7
13	Nut	A194-2H

NPS	Typical Dimensions(in)				Class 150Lb Flange Dimensions(in)							WT Lbs
	d	L	H	W	D	C	g	T	t	n	Φ	
1/2	1/2	4.25	3.43	5.12	3.5	2.38	1.38	0.37	0.06	4	5/8	4.4
3/4	3/4	4.62	3.54	5.12	3.88	2.75	1.69	0.4	0.06	4	5/8	5.28
1	1	5	3.82	5.91	4.25	3.12	2	0.44	0.06	4	5/8	7.92
1.1/2	1.1/2	6.5	5.04	7.87	5	3.88	2.88	0.56	0.06	4	5/8	14.52
2	2	7	5.31	7.87	6	4.75	3.62	0.62	0.06	4	3/4	22
2.1/2	2.1/2	7.5	6.22	11.81	7	5.5	4.12	0.68	0.06	4	3/4	31.9
3	3	8	7.72	13.78	7.5	6	5	0.75	0.06	4	3/4	42.9
4	4	9	8.35	15.75	9	7.5	6.19	0.94	0.06	8	3/4	72.6
5	5	14	9.06	24.56	10	8.5	7.31	0.94	0.06	8	7/8	110.5
6	6	15.5	11.26	32.68	11	9.5	8.5	1	0.06	8	7/8	136.4
8	8	18	14.88	40.94	13.5	11.75	10.62	1.12	0.06	8	7/8	235.4
10	10	21	16.26	41.14	16	14.25	12.75	1.18	0.06	12	1	334.4
12	12	24	19.68	45.87	19	17	15	1.25	0.06	12	1	532.7