



CLASS 300 STAINLESS STEEL FLOATING BALL VALVE

Fig# BL 300SS

Applicable Standards:

Steel Ball valves, ASME B16.34

Face to Face, ASME B16.10

End Flange, ASME B16.5

Inspection and Test, API 598

Design:

Valve MFG in Accordance with NACE

MR0175 Specifications

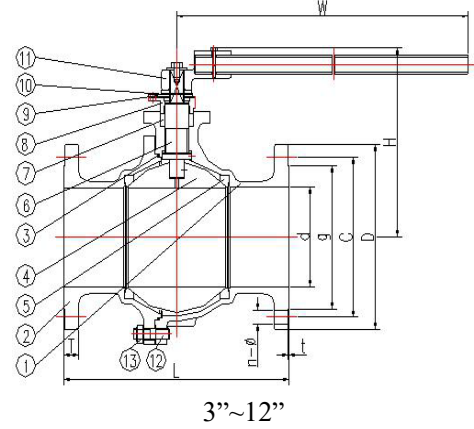
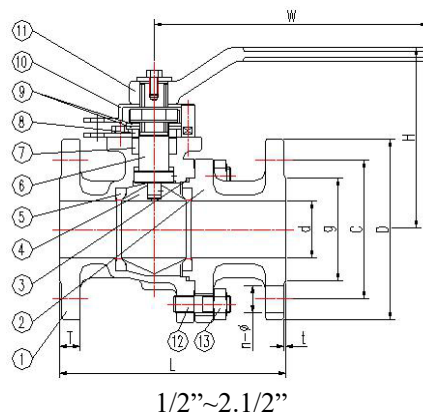

| NO | PART NAME | MATERIAL |
|----|------------|---------------|
| 1 | Body | A351-CF8M |
| 2 | Bonnet | A351-CF8M |
| 3 | Gasket | 316+Graphite |
| 4 | Ball | A276-316 |
| 5 | Ball Seats | PTFE/TFM1600 |
| 6 | Stem | A276-316 |
| 7 | Packing | PTFE/Graphite |

| NO | PART NAME | MATERIAL |
|----|--------------------|----------|
| 8 | Gland Flange | A351-CF8 |
| 9 | Belleville Washers | A276-301 |
| 10 | Lock Plate | A351-CF8 |
| 11 | Lever | Steel |
| 12 | Bonnet Bolt | A193-B8M |
| 13 | Nut | A194-8M |

| NPS | Typical Dimensions(in) | | | | Class 300Lb Flange Dimensions(in) | | | | | | | WT Lbs |
|-------|------------------------|-------|-------|-------|-----------------------------------|-------|-------|------|------|----|-------|-----------|
| | d | L | H | W | D | C | g | T | t | n | Φ | |
| 1/2 | 1/2 | 5.5 | 3.58 | 5.12 | 3.75 | 2.62 | 1.38 | 0.56 | 0.06 | 4 | 5/8 | 5.28 |
| 3/4 | 3/4 | 6 | 3.7 | 5.12 | 4.62 | 3.25 | 1.69 | 0.62 | 0.06 | 4 | 3/4 | 8.14 |
| 1 | 1 | 6.5 | 3.86 | 5.91 | 4.88 | 3.5 | 2 | 0.68 | 0.06 | 4 | 3/4 | 11 |
| 1.1/2 | 1.1/2 | 7.5 | 5.02 | 7.87 | 6.12 | 4.5 | 2.88 | 0.81 | 0.06 | 4 | 7/8 | 21.12 |
| 2 | 2 | 8.5 | 5.31 | 7.87 | 6.5 | 5 | 3.62 | 0.87 | 0.06 | 8 | 3/4 | 28.6 |
| 2.1/2 | 2.1/2 | 9.5 | 6.22 | 11.81 | 7.5 | 5.88 | 4.12 | 1 | 0.06 | 8 | 7/8 | 41.8 |
| 3 | 3 | 11.12 | 7.95 | 13.78 | 8.25 | 6.62 | 5 | 1.12 | 0.06 | 8 | 7/8 | 66 |
| 4 | 4 | 12 | 8.58 | 15.75 | 10 | 7.88 | 6.19 | 1.25 | 0.06 | 8 | 7/8 | 101.2 |
| 5 | 5 | 15 | 9.71 | 24.56 | 11 | 9.25 | 7.31 | 1.37 | 0.06 | 8 | 7/8 | 148.5 |
| 6 | 6 | 15.88 | 11.3 | 32.68 | 12.5 | 10.62 | 8.5 | 1.44 | 0.06 | 12 | 7/8 | 193.6 |
| 8 | 8 | 19.75 | 14.88 | 40.94 | 15 | 13 | 10.62 | 1.62 | 0.06 | 12 | 1 | 358.6 |
| 10 | 10 | 22.38 | 16.26 | 41.14 | 17.5 | 15.25 | 12.75 | 1.87 | 0.06 | 16 | 1.1/8 | 523.6 |
| 12 | 12 | 25.5 | 18.21 | 45.87 | 20.5 | 17.75 | 15 | 2 | 0.06 | 16 | 1.1/4 | 762.3 |