

CLASS 300 STAINLESS STEEL FLOATING BALL VALVE

Fig# BL 300SS

Applicable Standards:

Steel Ball valves, ASME B16.34

Face to Face, ASME B16.10

End Flange, ASME B16.5

Inspection and Test, API 598

Design:

Valve MFG in Accordance with NACE MR0175 Specifications

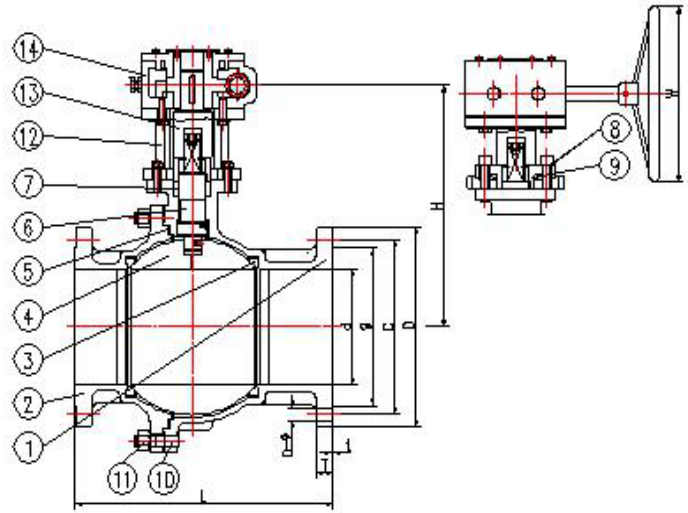

NO	PART NAME	MATERIAL
1	Body	A351-CF8M
2	Bonnet	A351-CF8M
3	Ball Seats	PTFE/TFM1600
4	Ball	A276-316
5	Gasket	316+Graphite
6	Stem	A276-316
7	Packing	PTFE/Graphite

NO	PART NAME	MATERIAL
8	Belleville Washers	A276-301
9	Gland Flange	A351-CF8
10	Bonnet Bolt	A193-B8M
11	Nut	A194-8M
12	Yoke	A351-CF8
13	Coupling	A276-420
14	Worm Gear Actuator	C.S

NPS	Typical Dimensions(in)				Class 300Lb Flange Dimensions(in)							WT Lbs
	d	L	H	W	D	C	g	T	t	n	Φ	
6	6	15.88	12.87	11.81	12.5	10.62	8.5	1.44	0.06	12	7/8	344
8	8	19.75	16.28	11.81	15	13	10.62	1.62	0.06	12	1	520
10	10	22.38	17.89	11.81	17.5	15.25	12.75	1.87	0.06	16	1.1/8	723
12	12	25.5	18.21	11.81	20.5	17.75	15	2	0.06	16	1.1/4	942