



CLASS 150 CARBON STEEL TRUNNION BALL VALVE

Fig# TBL 150CS

Applicable Standards:

- Steel Trunnion Ball valves, API 608
- Steel Trunnion Ball valves, ASME B16.34
- Face to Face, ASME B16.10
- End Flange, ASME B16.5
- Inspection and Test, API 598

Design:

Valve MFG in Accordance with NACE MR0175 Specifications

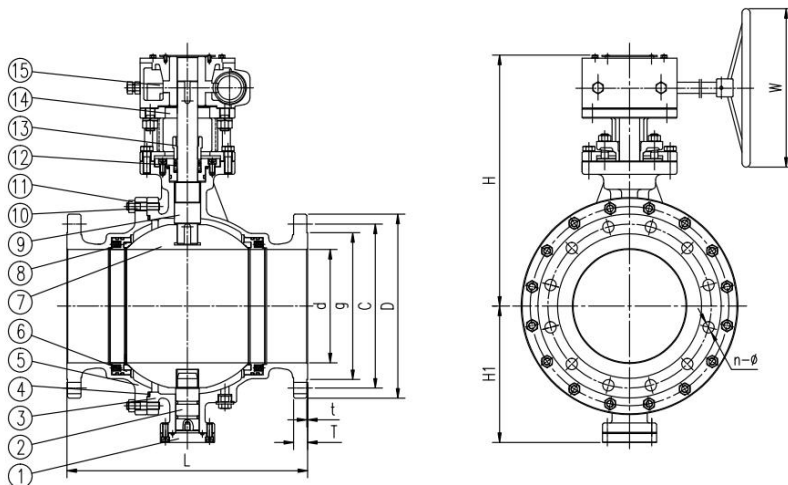

NO	PART NAME	MATERIAL
1	Cover	A216-WCB
2	Lower stem	A276-316
3	Body	A216-WCB
4	Gasket	304+Graphite
5	Bonnet	A216-WCB
6	Seat ring	A182-F316
7	Ball	A276-316
8	Seat	PTFE

NO	PART NAME	MATERIAL
9	Upper stem	A276-316
10	Bonnet bolt	A193-B7
11	Nut	A194-2H
12	Packing	PTFE
13	Gland flange	A216-WCB
14	Yoke	A216-WCB
15	Worm Gear Actuator	C.S

NPS	Typical Dimensions(in)						Class 150Lb Flange Dimensions(in)						WT Lbs
	d	L	H	H1	W	D	C	g	T	t	n	Φ	
2	2	7	6.02	4.12	7.87	6	4.75	3.62	0.62	0.06	4	3/4	33
2.1/2	2.1/2	7.5	6.5	5.34	7.87	7	5.5	4.12	0.68	0.06	4	3/4	38.4
3	3	8	7.68	6.05	7.87	7.5	6	5	0.75	0.06	4	3/4	83.6
4	4	9	8.39	6.83	11.02	9	7.5	6.19	0.94	0.06	8	3/4	143
5	5	14	10.07	7.81	11.02	10	8.5	7.31	0.94	0.06	8	7/8	215
6	6	15.5	12.40	8.43	11.02	11	9.5	8.5	1	0.06	8	7/8	260
8	8	18	15.42	10.24	11.81	13.5	11.75	10.62	1.12	0.06	8	7/8	440
10	10	21	17.17	11.85	13.78	16	14.25	12.75	1.18	0.06	12	1	803
12	12	24	19.13	14.21	17.72	19	17	15	1.25	0.06	12	1	1170
14	14	27	24.6	15.79	17.72	21	18.75	16.25	1.37	0.06	12	1.1/8	1420
16	16	30	28.35	18.59	17.72	23.5	21.25	18.5	1.44	0.06	16	1.1/8	1650
18	18	34	31	19.42	17.72	25	22.75	21	1.56	0.06	16	1.1/4	1970
20	20	36	33.1	22.41	17.72	27.5	25	23	1.68	0.06	20	1.1/4	2620
24	24	42	41.3	26.58	17.72	32	29.5	27.25	1.87	0.06	20	1.3/8	4620