



CLASS 300 STAINLESS STEEL TRUNNION BALL VALVE

Fig# TBL 300SS

Applicable Standards:

Steel Trunnion Ball valves, API 608

Face to Face, ASME B16.10

End Flange, ASME B16.5

Inspection and Test, API 598

Design:

Valve MFG in Accordance with NACE MR0175 Specifications

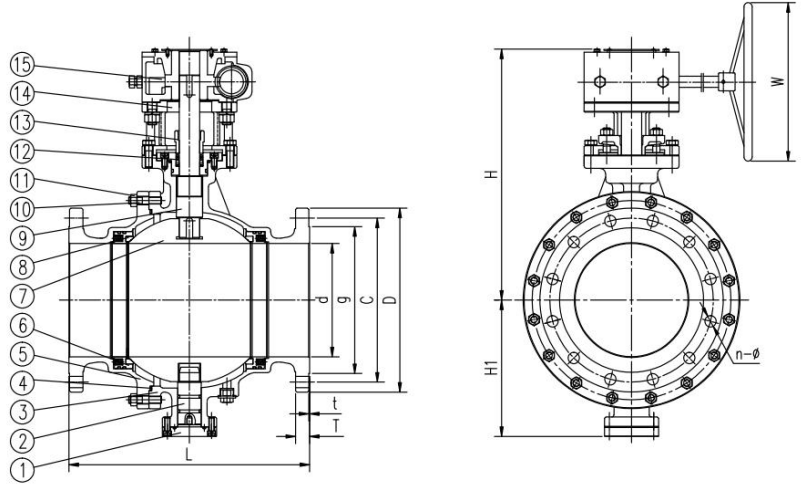

| NO | PART NAME | MATERIAL |
|----|------------|--------------|
| 1 | Cover | A351-CF8M |
| 2 | Lower stem | A276-316 |
| 3 | Body | A351-CF8M |
| 4 | Gasket | 316+Graphite |
| 5 | Bonnet | A351-CF8M |
| 6 | Seat ring | A182-F316 |
| 7 | Ball | A276-316 |
| 8 | Seat | PTFE |

| NO | PART NAME | MATERIAL |
|----|--------------------|----------|
| 9 | Upper stem | A276-316 |
| 10 | Bonnet bolt | A193-B8M |
| 11 | Nut | A194-8M |
| 12 | Packing | PTFE |
| 13 | Gland flange | A351-CF8 |
| 14 | Yoke | A351-CF8 |
| 15 | Worm Gear Actuator | C.S |

| NPS | Typical Dimensions(in) | | | | | Class 150Lb Flange Dimensions(in) | | | | | | | WT Lbs |
|-------|------------------------|-------|-------|-------|-------|-----------------------------------|-------|-------|------|------|----|-------|-----------|
| | d | L | H | H1 | W | D | C | g | T | t | n | Φ | |
| 2 | 2 | 8.5 | 6.02 | 4.12 | 7.87 | 6.5 | 5 | 3.62 | 0.87 | 0.06 | 8 | 3/4 | 40 |
| 2.1/2 | 2.1/2 | 9.5 | 6.5 | 5.34 | 7.87 | 7.5 | 5.88 | 4.12 | 1 | 0.06 | 8 | 7/8 | 59 |
| 3 | 3 | 11.13 | 7.68 | 6.05 | 7.87 | 8.25 | 6.62 | 5 | 1.12 | 0.06 | 8 | 7/8 | 104 |
| 4 | 4 | 12 | 8.39 | 6.83 | 11.02 | 10 | 7.88 | 6.19 | 1.25 | 0.06 | 8 | 7/8 | 176 |
| 5 | 5 | 15 | 10.07 | 7.81 | 11.02 | 11 | 9.25 | 7.31 | 1.37 | 0.06 | 8 | 7/8 | 232 |
| 6 | 6 | 15.88 | 12.40 | 8.43 | 11.02 | 12.5 | 10.62 | 8.5 | 1.44 | 0.06 | 12 | 7/8 | 260 |
| 8 | 8 | 19.75 | 15.42 | 10.24 | 11.81 | 15 | 13 | 10.62 | 1.62 | 0.06 | 12 | 1 | 440 |
| 10 | 10 | 22.38 | 17.17 | 11.85 | 13.78 | 17.5 | 15.25 | 12.75 | 1.87 | 0.06 | 16 | 1.1/8 | 803 |
| 12 | 12 | 25.5 | 19.13 | 14.21 | 17.72 | 20.5 | 17.75 | 15 | 2 | 0.06 | 16 | 1.1/4 | 1166 |
| 14 | 14 | 30 | 24.6 | 15.79 | 17.72 | 23 | 20.25 | 16.25 | 2.12 | 0.06 | 20 | 1.1/4 | 1630 |
| 16 | 16 | 33 | 28.35 | 18.59 | 17.72 | 25.5 | 22.5 | 18.5 | 2.25 | 0.06 | 20 | 1.3/8 | 2266 |
| 18 | 18 | 36 | 31 | 19.42 | 17.72 | 28 | 24.75 | 21 | 2.37 | 0.06 | 24 | 1.3/8 | 2900 |
| 20 | 20 | 39 | 33.1 | 22.41 | 17.72 | 30.5 | 27 | 23 | 2.5 | 0.06 | 24 | 1.3/8 | 3400 |
| 24 | 24 | 45 | 41.3 | 26.58 | 17.72 | 36 | 32 | 27.25 | 2.75 | 0.06 | 24 | 1.5/8 | 5720 |